

# INTERNATIONAL LASER CLASS ASSOCIATION MIDWINTERS WEST

March 23-25, 2018



IN CONJUNCTION WITH

## SCYYRA ULLMAN/FROST

March 24-25, 2018



Santa Barbara Yacht Club  
Santa Barbara, California, USA

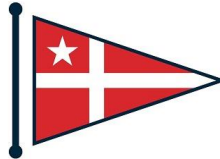

## SAILING INSTRUCTIONS

**[DP]** denotes a rule for which the penalty is at the discretion of the Jury.

**[NP]** denotes that a breach of this rule will not be grounds for a protest by a boat.

**[SP]** denotes a rule for which a standard penalty may be applied by the race committee without a hearing

The Organizing Authority for the 2018 Laser Midwinters West will be The Santa Barbara Yacht Club (SBYC), 130 Harbor Way, Santa Barbara, CA 93109 on behalf of the International Laser Class Association (ILCA)

### 1. RULES

- 1.1. The regatta will be governed by the rules as defined in *The Racing Rules of Sailing*.
- 1.2. The US Sailing prescriptions to rules 60, 63.2 and 63.4 are deleted.
- 1.3. For those boats also competing in the Ullman/Frost Series the [2017-2018 Ullman/Frost Notice of Race](#) will apply.
- 1.4. Racing Rules 40, 62.2, 66, A4, and A5 will be changed as follows:
  - Rule 40 will be changed as follows: Competitors shall wear personal flotation devices while racing, except briefly while changing or adjusting clothing or personal equipment.
  - Rules 62.2 and 66 will be changed to shorten the time limit for a request for redress and for reopening of protest hearings.
  - Rules A4 and A5 will be changed to state, that a boat starting later than 4 minutes after her starting signal will be scored Did Not Start.

The changes will appear in full in the sailing instructions. The sailing instructions may also change other racing rules.

- 1.5. Appendix P "Special Procedures for Rule 42" will apply and is changed as follows:
  - In P2.1 – First Penalty, the word 'first' is deleted and P2.2 and P2.3 are deleted.

### 2. NOTICES TO COMPETITORS

- 2.1. Notices to competitors will be posted on the official notice board located at the southeast corner of the launch ramp area adjacent to the check-in table. All official regatta notices will be posted here.

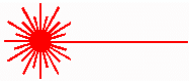

# INTERNATIONAL LASER CLASS ASSOCIATION MIDWINTERS WEST



- 2.2. Notices of protests will be posted on the protest notice board located at the southeast corner of the launch ramp area adjacent to the check-in table.

### 3. CHANGES TO SAILING INSTRUCTIONS

Any change to the sailing instructions will be posted before 1000 on the day it will take effect, except that any change to the schedule of races will be posted by 2000 on the day before it is to take place.

### 4. SIGNALS MADE ASHORE

- 4.1. Signals made ashore will be displayed from the flagpole on the UCSB dock.
- 4.2. When flag AP is displayed ashore. '1 minute' is replaced with 'not less than 60 minutes' in the race signal AP. This changes RRS Race Signals, AP.

### 5. SCHEDULE OF RACES

Friday March 23, 2018	1255	Warning Signal for 1st race of the day Subsequent races to start ASAP
Saturday March 24, 2018	1255	Warning Signal for 1st race of the day Subsequent races to start ASAP
Sunday March 25, 2018	1255 1530 After Racing	Warning Signal for 1st race of the day Subsequent races to start ASAP No First Warning Signal after this time Awards Presentation at the launch ramp (this changes the NOR)

- 5.1. A maximum of ten (10) races are scheduled: three (3) races on Friday, four (4) races on Saturday, and three (3) races on Sunday. The Race Committee (RC) may run fewer races at its discretion.
- 5.2. To alert boats that a race or sequence of races will begin soon, the orange starting flag will be displayed with one sound at least five minutes before a warning signal is made.
- 5.3. On the last day of racing no first warning signal will be made after 1530.

### 6. CLASS FLAGS

Class flags will be:

Class	Flag
Laser Standard	White with red laser logo
Laser Radial	Green with red laser logo

### 7. RACING AREAS

- 7.1. Location of racing areas will be as shown in Addendum B.



# INTERNATIONAL LASER CLASS ASSOCIATION MIDWINTERS WEST



## 8. THE COURSES

- 8.1. The diagrams in Addendum A show the courses, including the approximate angles between legs, the order in which marks are to be passed, and the side on which each mark is to be left.
- 8.2. The course shall be signaled by placards displayed on the race committee signal boat.
- 8.3. No later than the warning signal, the race committee signal boat will display the approximate compass bearing of the first leg.

## 9. MARKS

- 9.1. Marks 1, 1A, 4P, 4S, and 5 will be orange inflatable shapes.
- 9.2. Marks 2, 3P, 3S, will be yellow inflatable shapes.
- 9.3. Marks shall be rounded to port. When there is a gate, boats shall sail between the gate marks from the direction of the previous mark and round either gate mark. If one of the gate marks is missing, boats shall round the remaining mark to port.
- 9.4. New marks, as provided in instruction 11.1, will be a different color from the original.
- 9.5. The starting mark will be an orange inflatable shape
- 9.6. The finishing mark will be a yellow inflatable shape.

## 10. THE START

- 10.1. The starting line will be between the course side of the starting mark and a staff displaying an orange flag on the Race Committee Signal Boat.
- 10.2. Boats whose warning signal has not been made shall avoid the starting area during the starting sequence. [DP]
- 10.3. A boat starting later than 4 minutes after her starting signal will be scored Did Not Finish without a hearing. This changes rule A4 and A5.
- 10.4. The race committee may attempt to hail OCS boats. Failure of the committee to make the attempt or for the competitor to hear the hail will not be grounds for redress. This changes rule 62.1.

## 11. CHANGE OF THE NEXT LEG OF THE COURSE

- 11.1. To change the next leg of the course, the race committee will lay a new mark (or move the finishing line) and remove the original mark as soon as practicable. When in a subsequent change a new mark is replaced, it will be replaced by an original mark.

## 12. THE FINISH

- 12.1. The finishing line will be between the course side of the finishing mark and a staff displaying an orange flag on the Race Committee Signal Boat.

## 13. PENALTY SYSTEM

- 13.1. Appendix P, Special Procedures for Rule 42, will apply as changed by SI 13.2
- 13.2. RRS P2.2 and P2.3 will not apply and RRS P2.1 is changed so that it will apply to all penalties.

## 14. TIME LIMITS AND TARGET TIMES

- 14.1. Time limits and target times are as follows:

<u>Time Limit</u>	<u>Mark 1 Time Limit</u>	<u>Target Time</u>
90	30	40

If no boat has passed Mark 1 within the Mark 1 time limit the race will be abandoned. Failure to meet the target time will not be grounds for redress. This changes rule 62.1(a).

- 14.2. Boats failing to finish within fifteen (15) minutes after the first boat sails the course and finishes will be scored Did Not Finish without a hearing. This changes rules 35, A4 and A5.



# INTERNATIONAL LASER CLASS ASSOCIATION MIDWINTERS WEST



## 15. PROTESTS AND REQUESTS FOR REDRESS

- 15.1. Protest forms are available adjacent to the Notice Board. Protests and requests for redress or reopening shall be delivered there within the appropriate time limit.
- 15.2. For each fleet, the protest time limit is 30 minutes after the race committee signal boat arrives at the dock.
- 15.3. Notices will be posted no later than 30 minutes after the protest time limit to inform competitors of hearings in which they are parties or named as witnesses. This will constitute notification required by rule 63.2. Hearings will be held in the protest room, located within the protest office, in the approximate order as received.
- 15.4. Notices of protests by the race committee or protest committee will be posted to inform boats under rule 61.1(b).
- 15.5. Breaches of instructions marked **[NP]** will not be grounds for a protest by a boat. This changes rule 60.1(a). Penalties for these breaches may be less than disqualification if the protest committee so decides.
- 15.6. Penalties for breaches of instructions marked **[DP]**, are at the discretion of the Protest Committee. Penalties for these breaches may be less than disqualification if the protest committee so decides.
- 15.7. On the last scheduled day of racing a request for reopening a hearing shall be delivered
  - 1.1.1. within the protest time limit if the requesting party was informed of the decision on the previous day;
  - 1.1.2. no later than 30 minutes after the requesting party was informed of the decision on that day.This changes rule 66.
- 15.8. On the last scheduled day of racing a request for redress from a protest committee decision shall be delivered no later than 30 minutes after the decision was posted. This changes rule 62.2.

## 16. SCORING

- 16.1. Three (3) completed races shall constitute a series.
- 16.2. When fewer than five (5) races have been completed, a boat's series score will be the total of her race scores.

## 17. SAFETY REGULATIONS

- 17.1. Competitors shall either wear a US Coast Guard-approved flotation device, or a flotation device that conforms to regulations of their own country while on the water, other than for brief periods while adding or removing clothing. **[DP]**
- 17.2. Check-Out and Check-In Procedures: Before the warning signal on the first race each day, all boats shall sail by the stern of the race committee signal boat, hail her sail number and obtain the acknowledgment of the race committee. **[DP]**
- 17.3. A boat that retires from a race shall notify the race committee as soon as possible. **[DP]**

## 18. REPLACEMENT OF CREW OR EQUIPMENT

- 18.1. Substitution of competitors will not be allowed.
- 18.2. Substitution of damaged or lost equipment will not be allowed unless authorized by the race committee. Requests for substitution shall be made to the committee at the first reasonable opportunity, which may be after the substitution. **[DP]**



# INTERNATIONAL LASER CLASS ASSOCIATION MIDWINTERS WEST



## 19. EQUIPMENT AND MEASUREMENT CHECKS

A boat or equipment may be inspected at any time for compliance with the class rules and sailing instructions.

## 20. EVENT ADVERTISING

Boats may be required to display event advertising chosen and supplied by the organizing authority. [DP]

## 21. OFFICIAL BOATS

Official boats will be marked as follows:

Race Committee Signal Boat	Blue flag marked with white 'RC' & red anchor
Race Committee Boats	Yellow or blue flag marked with white 'RC' & red anchor
Judges Boat	Code flag 'J'

## 22. SAFETY AND ADULT RESPONSIBILITY

- 22.1. Competitors shall either wear a US Coast Guard-approved flotation device, or a flotation device that conforms to regulations of their own country.
- 22.2. It is the responsibility solely of the parent(s) of any competitor under the age of eighteen (18), or in the instance of the competitor who is eighteen (18) or over, the competitor, to decide if the competitor should sail in the weather and sea conditions that might arise during the event.
- 22.3. Parents of competitors under the age of eighteen (18) not personally attending any part of the event shall ensure that another adult is authorized and designated to make these decisions for their child.
- 22.4. The designated adult shall accept full responsibility for all actions of the competitor during any activity related to the event. This includes on-shore activities before, during, and after the regatta.

## 23. SUPPORT/COACH/SPECTATOR BOATS [DP]

- 23.1. Support/coach/spectator boats shall register with the Regatta Headquarters, as shown in 'Attachment H – SB Harbor Map' during the registration period.
- 23.2. A unique registration number will be assigned to each support boat. Support, coach, spectator boats shall prominently display their assigned coach flag at all times while on the water.
- 23.3. Coaches and supporters are required to monitor the course channel on their VHF radios and be available to assist with safety when requested. Coaches are expected to attend the coaches meeting each morning.

## 24. TRASH DISPOSAL [NP]

Trash may be placed aboard support and race committee boats.

## 25. BERTHING [DP] [NP]

- 25.1. Competitors' boats shall be stored overnight in the Santa Barbara Harbor Public Launch Ramp area as shown in 'Attachment H – SB Harbor Map'. Each boat must have its own dolly. Road Trailers may be stored in yellow parking stalls other than the back row of the Santa Barbara Harbor Public Launch Ramp area. Applicable Santa Barbara Harbor Lot parking fees will apply.
- 25.2. Coach boats may be stored in the water overnight at the UCSB docks on a first come-first serve basis as shown in 'Attachment H'. Once the UCSB docks are full, coach boats may be stored in the water overnight on End Tie 'D' as shown in 'Attachment H'.
- 25.3. Spectator and additional support boats may be stored in the water overnight on End Tie 'D' on a first come- first serve basis.



# INTERNATIONAL LASER CLASS ASSOCIATION MIDWINTERS WEST



## 26. HAUL-OUT RESTRICTIONS [DP] [NP]

No boat may be stored overnight on the grounds of Santa Barbara Yacht Club.

## 27. RADIO COMMUNICATIONS

Except in an emergency, a boat shall neither make radio transmissions while racing nor receive radio communications not available to all boats. This restriction also applies to mobile telephones.

## 28. PRIZES

Prizes will be awarded after racing on Sunday in accordance with the Laser class guidelines.

## 29. DISCLAIMER OF LIABILITY

Competitors participate in the regatta entirely at their own risk. See rule 4, Decision to Race. The organizing authority will not accept any liability for material damage or personal injury or death sustained in conjunction with or prior to, during, or after the regatta.

## 30. FURTHER INFORMATION

Additional useful information regarding accommodations, travel, boat charters, equipment services and area recreation are available at <https://sbyc.org/2018-laser-midwinters-west> or contact the SBYC Race office [racing@sbyc.org](mailto:racing@sbyc.org) or +1 805 965 8112.

**Event Chair:** Craig Scheiblaue (805) 452-6582 [craig.scheiblaue@gmail.com](mailto:craig.scheiblaue@gmail.com)

**PRO:** Mark Townsend, IRO

**Chief Judge:** Michael Gross, NJ

**Charter Boats** will be available from Vela LA

For further information please contact:

Michael Bradley

(844) 216-9607

[www.Vela-la.com](http://www.Vela-la.com)



# INTERNATIONAL LASER CLASS ASSOCIATION MIDWINTERS WEST



## ADDENDUM A

*Shown here are diagrams of course shapes. The boat's track is represented by a discontinuous line.*

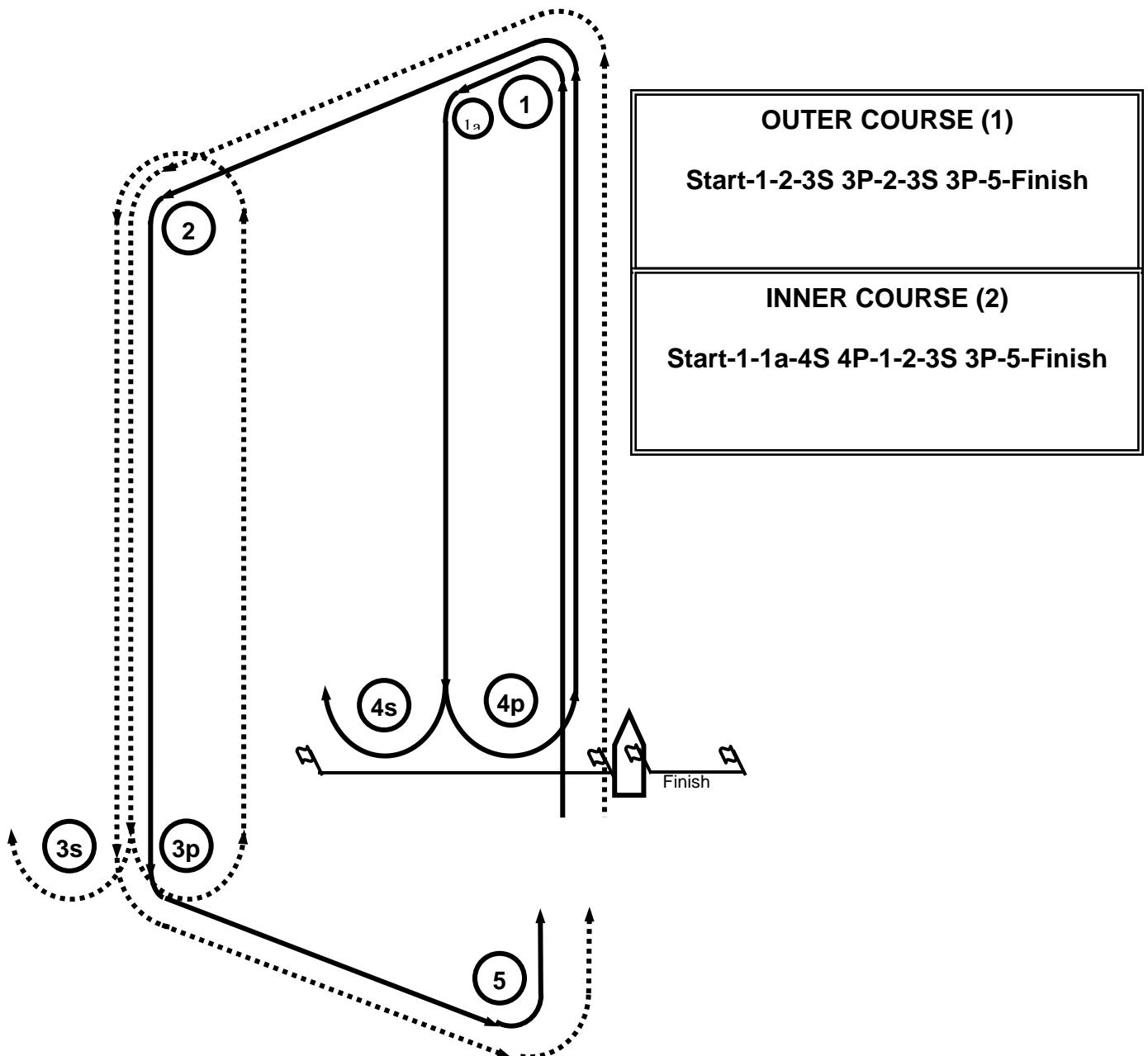



# INTERNATIONAL LASER CLASS ASSOCIATION MIDWINTERS WEST



## ADDENDUM B

*Shown here is the racing area.*

